

H. K. SMITH.  
LATHE REST.

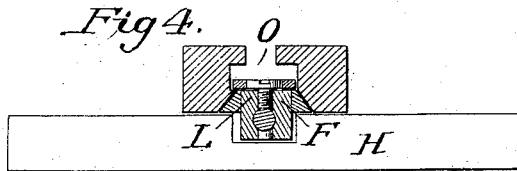
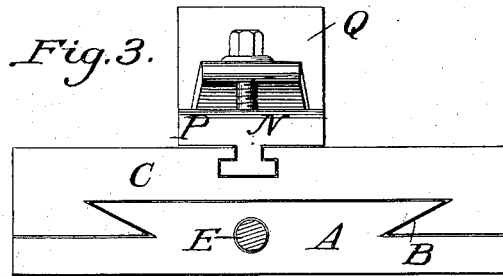
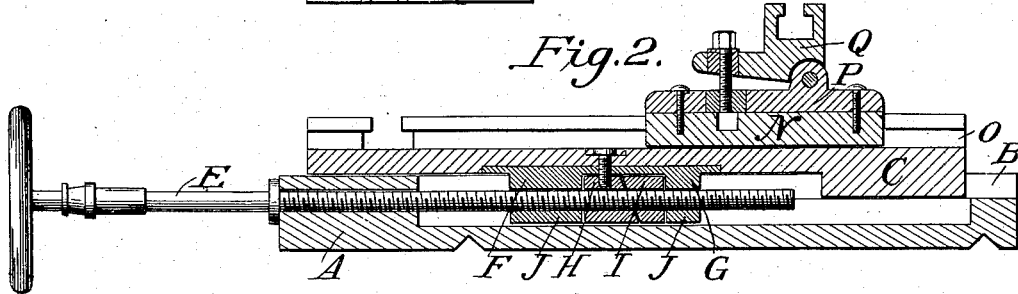
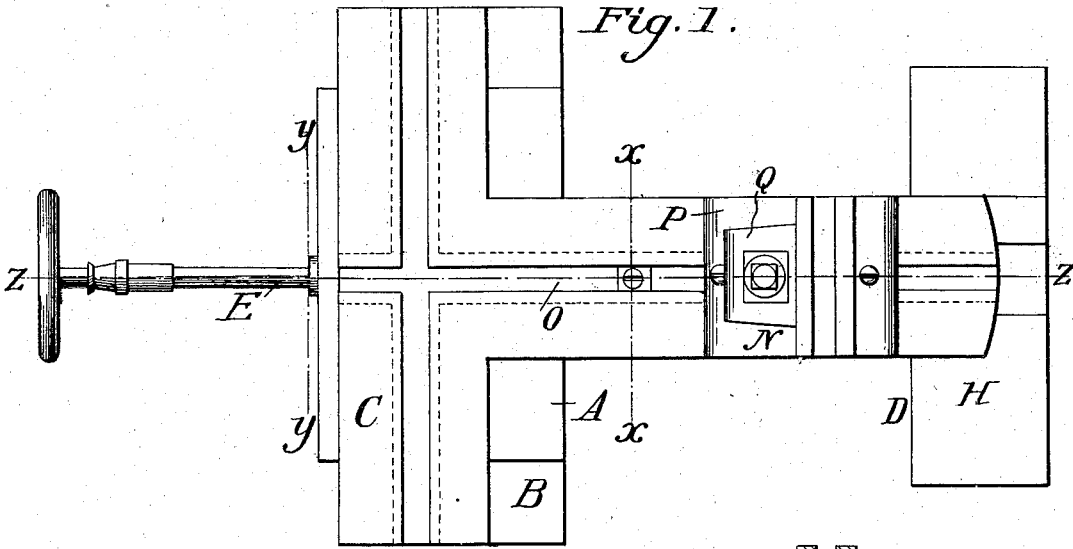

Witnesses:  
*Chas. Ince*  
*J. A. Fraser*

Inventor.  
*H. K. Smith*  
 Per *Munnell*  
*Attorneys*

# United States Patent Office.

H. K. SMITH, OF NORWICH, CONNECTICUT.

Letters Patent No. 74,621, dated February 18, 1868.

## IMPROVED LATHE-REST.

The Schedule referred to in these Letters Patent and making part of the same.

### TO ALL WHOM IT MAY CONCERN:

Be it known that I, H. K. SMITH, of Norwich, in the county of New London, and State of Connecticut, have invented certain new and useful Improvements in Lathe-Rests; and I do hereby declare that the following is a full, clear, and exact description thereof, which will enable others skilled in the art to make and use the same, reference being had to the accompanying drawings forming part of this specification.

The present invention consists, first, in constructing the nut through which the screw-shaft works, for carrying the frame on which the block holding the lathe-cutting tool is arranged, so as to move the tool toward or away from the article on which it is to act, in such a manner that such nut, should the said screw work loose or play from side to side, can be tightened up thereon. In the accompanying plate of drawings my improvements in lathe-rests are illustrated—

Figure 1 being a longitudinal plan or top view of a lathe-rest, made according thereto.

Figure 2, a vertical section taken in the plane of the line  $z z$ , fig. 1.

Figure 3, a transverse vertical section, taken in the plane of the line  $y y$ , fig. 1.

Figure 4, a transverse vertical section, taken in the line  $x x$ , fig. 1, the sliding tool-carrier being removed. Similar letters of reference indicate corresponding parts.

A, in the drawings, represents the lower frame or base portion to the rest of the lathe, on which frame, in a dove-tail groove, B, thereof, another frame, C, is arranged to slide forward to and backward from the inner end D, to the frame-rest H, by and through the turning of the screw-shaft E, either to the right or left, as the case may be, that acts upon the nut F, fixed to the under side of the said frame C. This nut, in lieu of being made of one piece, as heretofore, is made in three parts, G, H, and I, with the one, G, fixed to the frame, and by its extension side-pieces J, forming a groove or recess for the reception of the other two parts, H and I, of the nut, that are each upon one end made with a bevel or taper, as shown, and with the centre or intermediate part H arranged by the action of a screw, L, to be forced in such a direction as to shorten or lengthen the nut, according as may be desired, by acting upon the lateral movable part thereof, and thus enabling the nut to be adjusted to a perfect operation, and prevent all backlash or loose working of the screw and the frame moved by it. N a block, arranged to move on frame to lathe-rest, in a groove, O, of which it is susceptible of being moved forward to or backward from the work. This block carries the cutting-tool, and for the purpose of inclining the same in a direction either more or less toward the work, is made in two parts, Q and P, hinged together at their inner ends, and at their outer ends provided with divided nuts and a set-screw, as and for the purpose described in the schedule annexed to and forming a part of the Letters Patent granted to me on the first day of January, A. D. 1867.

I claim as new, and desire to secure by Letters Patent—

The nut F, made in three parts, G, H, and I, arranged-together with screws L and E, for operation substantially as and for the purpose described.

The above specification of my invention signed by me, this 27th day of September, 1867.

H. K. SMITH.

Witnesses:

WM. F. McNAMARA,  
ALBERT W. BROWN,